



**MITSUBISHI ELECTRIC AUTOMATION (THAILAND) CO., LTD.**

Bang-Chan Industrial Estate No. 111 Moo 4, Serithai Rd., T.Kannayao, A.Kannayao, BKK 10230 Thailand  
Tel: (66) 2517-1326, (66) 2919-9873 Fax: (66) 2517-1328 URL: www.meath-co.com E-mail: support@meath.co.th

**บริษัท มิทซูบิชิ อิเล็กทริก ออโตเมชัน (ประเทศไทย) จำกัด**

นิติบุคคลสาขารวมบางชั้น เลขที่ 111 หมู่ 4 ถนนเสรีไทย แขวงคันทนาয়া เขตคันทนาয়া กทม. 10230

โทรศัพท์: (66) 2517-1326, (66) 2919-9873 โทรสาร: (66) 2517-1328 URL: www.meath-co.com E-mail: support@meath.co.th

**MOTOR SPECIFICATION SHEET**

MODEL : SB-JR 7.5HP 6P (HT)

USED FOR : STANDARD

DESCRIPTION	DETAIL				
PHASE	3				
MODEL NAME	SB-JR				
RATED OUTPUT, HP (kW)	7.5 (5.5)				
POLE	6				
CODE					
OUTLINE DRAWING NO.	ONM24O188-*				
RATED VOLTAGE (V)	380	415	380	440	
RATED FREQUENCY (Hz)	50	50	60	60	
RATED CURRENT (A)	12.8	13.0	12.1	11.5	
RATED SPEED (min <sup>-1</sup> )	950	960	1140	1150	
THERMAL CLASS	155(F)				
RATING	S1 (CONTINUOUS)				
ENCLOSURE CONSTRUCTION	DRIP-PROOF				
DEGREES OF PROTECTION	IP22				
METHOD OF COOLING	IC01				
FRAME NO.	132M				
WEIGHT (kg)	61				
STANDARD	IEC 60034-1, JEC-2137-2000				
INSTALLATION	FOOT MOUNTED				
ROTATION	CCW (VIEWED FROM SHAFT END)				
BEARING	LOAD SIDE : 6308ZZ				
	OPPOSITE SIDE : 6207ZZ				
BEARING GREASE	UREA GREASE				
NOISE (dB.A)	64				
VIBRATION	V10				
CIRCUMSTANCE CONDITION	AMBIENT TEMPERATURE : -20 ~ +40°C				
	AMBIENT HUMIDITY : 85%RH OR LESS				
	ABOVE SEA LEVEL : 1000m OR LESS				
	ENVIRONMENT : NO BURSTING/EROSIVE GAS OR VAPOR				
COLOR	MUNSELL N5.5 (GRAY)				
TERMINAL BOX	NO. OF LEAD WIRES : 6				
	SOURCE CONNECTION : TERMINAL BLOCK				
INSULATION RESISTANCE	BY DC 500V MEGGER - ≥100MΩ				
DIELECTRIC TEST	AC 50Hz 1800V - 1min. (Based on rated voltage 380V)				
SHAFT SWING	≤0.03mm				
MATERIAL	FRAME : STEEL PLATE				
	BRACKET : ALUMINIUM				
	SHAFT : CARBON STEEL				
	STATOR CORE : ELECTRICAL STEEL				
	WIRE : ENAMELLED COPPER MAGNET WIRE				
	INSULATOR : POLYESTER FILM SATURATED WITH RESIN				
	VARNISH : EPOXY DENATURALIZATION POLYESTER				
	ROTOR CORE : ELECTRICAL STEEL				
	CONDUCTOR : ALUMINIUM				
	TERMINAL BOX : STEEL PLATE				
	PAINTING : ALKYD-NITROCELLULOSE RESIN				
PRODUCTION COUNTRY	THAILAND				

Specifications subject to change without notice.

<b>SPECIFICATION SHEET NO.</b>				
SS-M-2576-A				

MODEL SB-JR THREE PHASE INDUCTION MOTOR OUTLINE DRAWING

DRIP-PROOF TYPE  
DEGREES OF PROTECTION IP22

CUSTOMER \_\_\_\_\_  
USER \_\_\_\_\_  
FOR \_\_\_\_\_  
CUSTOMER'S ORDER NO. \_\_\_\_\_  
QUANTITY \_\_\_\_\_  
MFG. ORDER NO. \_\_\_\_\_

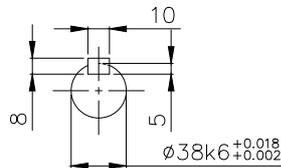
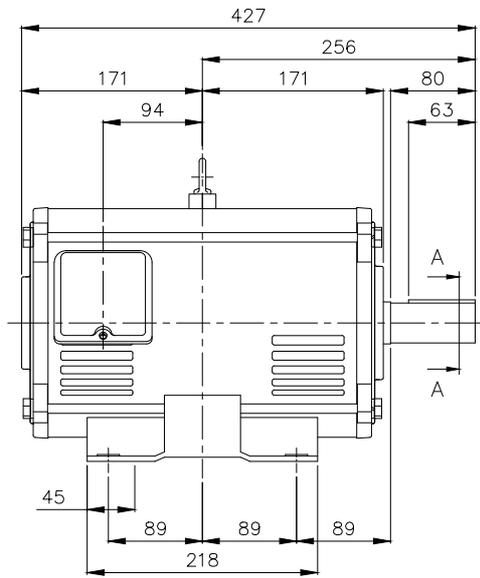

SECTION A-A

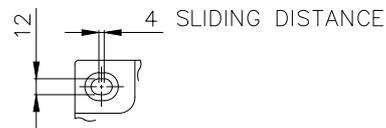
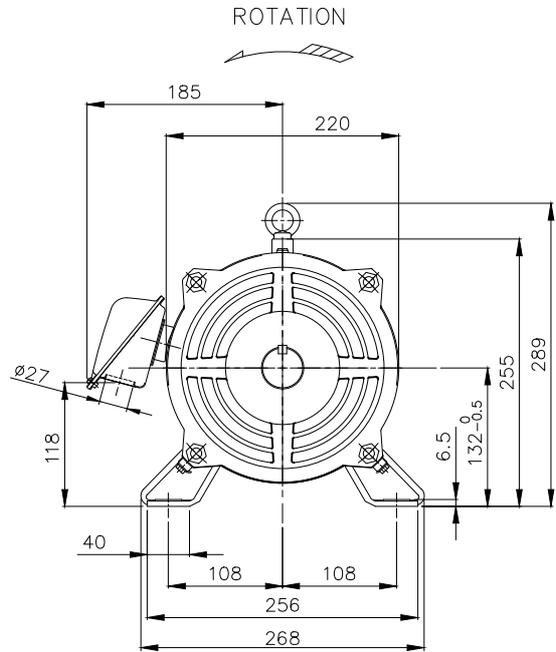

FRAME FOOT AS VIEWED FROM BELOW

YOUR ORDER	FRAME SIZE	RATING	TH. CLASS	AMB. TEMP.	BEARINGS		COLOR	DIRECTION OF ROTATION	NO. OF LEAD WIRES	REMARKS
					LOAD SIDE	OPP. SIDE				
	132M	S1 (CONT.)	155(F)	40°C	6308ZZ	6207ZZ	GRAY (MUNSELL N5.5)	CCW	6	

YOUR ORDER	OUTPUT		POLES	VOLT	HERTZ	REMARKS
	HP	kW				
	10	7.5	4	220/380/415	50	LT
				220/440	60	
	7.5	5.5	6	220/380/415	50	LT
				220/440	60	
	10	7.5	4	380/415	50	HT
				380/440	60	
	7.5	5.5	6	380/415	50	HT
				380/440	60	

MITSUBISHI ELECTRIC AUTOMATION (THAILAND) CO., LTD.

		OUTLINE DRAWING NO.	REV.
	DIMENSION IN mm.	0 N M 2 4 0 1 8 8	*
SCALE : NTS			